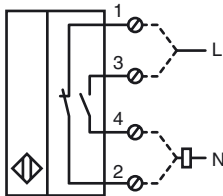
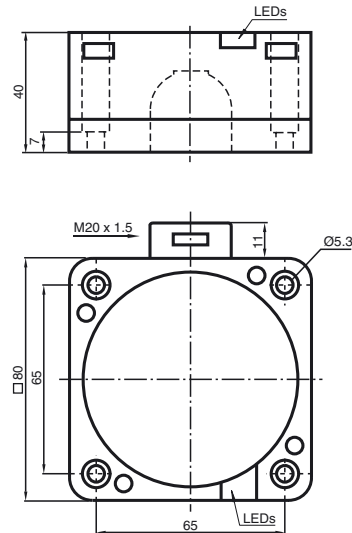

**Model Number**

NCB40-FP-W-P1

Features

- Comfort series
- 40 mm embeddable

Connection**Dimensions****Technical Data****General specifications**

Switching element function	AC	NO/NC
Rated operating distance	s_n	40 mm
Installation		embeddable
Output polarity		AC
Assured operating distance	s_a	0 ... 32.4 mm
Reduction factor r_{AI}		0.25
Reduction factor r_{Cu}		0.23
Reduction factor r_{V2A}		0.85

Nominal ratings

Operating voltage	U_B	20 ... 253 V
Switching frequency	f	0 ... 20 Hz
Hysteresis	H	typ. 3 %
Short-circuit protection		no
Voltage drop	U_d	≤ 5 V typ. 4V
Momentary current (20 ms, 0.1 Hz)		≤ 4000 mA
Operating current	I_L	5 ... 500 mA
Off-state current	I_r	0.3 ... 1 mA typ. 0.7 mA
Operating voltage display		LED, green
Indication of the switching state		LED, yellow

Ambient conditions

Ambient temperature	-25 ... 70 °C (-13 ... 158 °F)
---------------------	--------------------------------

Mechanical specifications

Connection type	screw terminals
Core cross-section	up to 2.5 mm ²
Housing material	PBT
Sensing face	PBT
Protection degree	IP68
Note	1) In the temperature range below 0 °C, permissible operating voltage U_B 80...253 V Safety fuse ≤ 2 A (quick-blow) according to IEC 60127-2 Sheet 1 Recommendation: after a short circuit, check that the device is functioning correctly.

Compliance with standards and directives

Standard conformity	
Standards	EN 60947-5-2:2007 IEC 60947-5-2:2007

Approvals and certificates

UL approval	cULus Listed, General Purpose
CSA approval	cCSAus Listed, General Purpose
CCC approval	Certified by China Compulsory Certification (CCC)

These sensors are especially designed for embeddable mounting in conveyor floors. Due to its precise location in metal base plates the sensor is afforded a high degree of mechanical protection. No clearance is required between the sensor and the base plate, avoiding the need for protective guarding to prevent possible foot injury.

The large sensing range ensures positive detection, and thus provides consistent control and monitoring of the conveyor.

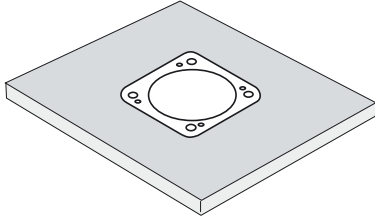

These sensors are especially designed for embeddable mounting in conveyor floors. Due to its precise location in metal base plates the sensor is afforded a high degree of mechanical protection. No clearance is required between the sensor and the base plate, avoiding the need for protective guarding to prevent possible foot injury.

The large sensing range ensures positive detection, and thus provides consistent control and monitoring of the conveyor.

